



Divider Block Lubrication Systems

- Divider Blocks
- Cycle Indicators
- Proximity Switches
- Check Valves
- Pressure Indicators
- Lube Oil Monitors
- Pumps
- No-Flow Shutdown Devices

Type this link in your web browser for a complete animated overview of

“How the Divider Block System Works”

ENGLISH – www.photogroup-inc.com/cctftp/VideoPlayer.html

SPANISH – www.photogroup-inc.com/cctftp/VideoPlayerSp.html

MANDARIN/CHINESE – www.photogroup-inc.com/cctftp/VideoPlayerCh.html

***Innovative Products for Reliable
Lubrication and Protection of
Gas Engines and Compressors***

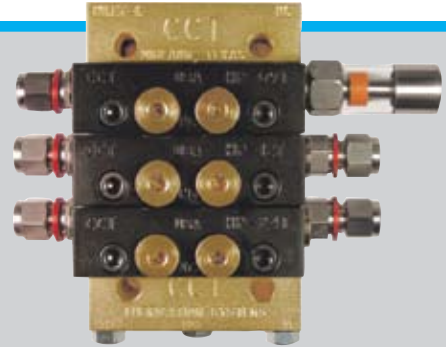

www.c-p-i.com www.progressive-equipment.com • www.cct.nu

CPI Lubrication Group

PROTECTING COMPRESSORS WORLDWIDE



CPI – CC Technology, 3201 West Wall St. Midland, Texas, 79701
Office: (432) 520-6700 - Fax: (432) 520-6707
U.S. & Canada Toll Free: 1-800-664-4033
www.cct.nu



CPI – Premier & Progressive Lubrication
14028 Aston Avenue, Houston, Texas 77040, USA
Phone: (713) 462-1061 - Fax: (713) 462-4027
www.progressive-equipment.com

**CPI Lubrication Offers On-Site Technical Field Service and Support...
Divider Block System Design, Complete Installation, Diagnostics and Trouble Shooting.**

➤ **Positive Lubrication to Cylinders/Packing:**

“CCT-HP” divider blocks give you the closest piston to valve tolerance in the world! 80 to 90 millionths-of-an-inch assures you precision lubrication of vital components, plus superior piston stalling for positive shutdown of the system should tubing be crushed or lubrication points become plugged.

➤ **O-Ring Seals on Outlet Sections:**

Eliminates thread sealants on outlets and ensures exceptional sealing and ease of assembly.

➤ **Reduced Torque for Mounting Screws:**

Reduce torque for mounting blocks on base section (65 in. lbs.) assures leak free operation to 7,500 PSI.

➤ **Wide Range of Piston Sizes:**

Enables efficient design for cylinder and packing lubrication quantities.

➤ **One Piece O-Ring Seal Outlet Checks:**

Assures reliable operation of the divider block system and eliminates oil leak problems.

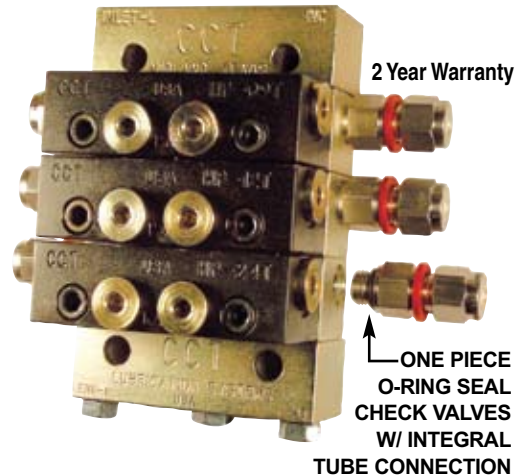

2 Year Warranty
5 YEAR WARRANTY ON BASE PLATE CHECK VALVES



Accessories for All Divider Block Systems

2 Year Warranty NeoMag Cycle Indicator

Protected by U.S. patent #7,461,670 B1 - US D570,236 S, US D591,627 S & US D613,631 S

The NeoMag visual cycle indicator follows the divider block piston movement so the operator can monitor and control oil consumption, set lube rates and easily spot problems in the divider block system.

Part# NMT for CCT, Graco/Trabon, Ariel, Lubriquip & SB Divider Blocks.
Part# NML for Lincoln & Part# NMD for Dropsa.

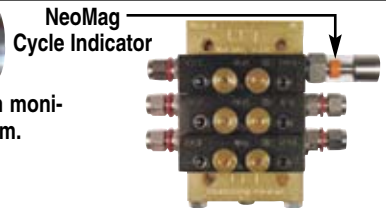

2 Year Warranty Captured Proximity Switch

Protected by U.S. Patent # 6,823,270

The proximity switch sends a switch closure with each cycle of the divider block to the control panel, PLC or the proflo PF1, to monitor oil consumption and shutdown the compressor if the lubrication system begins to deteriorate.

Part# TPSO for CCT, Graco/Trabon, Ariel, Lubriquip & SB Divider Blocks.
Part# LPS for Lincoln & Part# DPS for Dropsa Divider Blocks.



All components are enclosed in the magnet assembly. Never lose a spring, spacer or magnet again. Springs tested to 20 million cycles NO Broken Springs.

2 Year Warranty Reset Pressure Indicators

The reset pressure indicator identifies tubing or lubrication point blockage to enable the operator to quickly verify exactly which point is causing high pressure in the system.

Part# TRPI for CCT, Graco/Trabon, Ariel, Lubriquip & SB Divider Blocks.
Part# LRPI for Lincoln & Part# DRPI for Dropsa Divider Blocks.

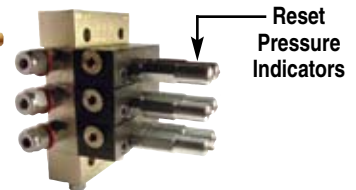

5 Year Warranty Base Plate Outlet Check Valves

U.S. Patent Pending

The base plate outlet check valve assures reliable operation of the divider block system. The o-ring seal check valve and integral tube connection eliminates leaks in the system.

Part# 421PR-OR for CCT base plates.
Part# 421PR-NPT for Graco/Trabon, SB, Ariel, Lubriquip, Lincoln & Dropsa base plates.

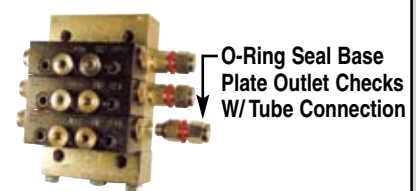

No-Flow Devices to Protect Your Compressor

- **Trends and Stores Divider Block System Operation to Monitor and Prove:**
 - Oil Consumption (Over and Under Lubrication)
 - Lubricator Pump Failure
 - Divider Block Failure
 - Compressor Component Failure (Rings, Rod, Packing and Cylinders)
 - Compressor Run Time
- **Shuts Down Compressor when Lubrication System Fails or Begins to Deteriorate:**
 - Adjustable Alarm Time
 - Normally Open or Normally Closed Operation
- **Installs on Divider Block or in Control Panel**
- **Wireless (IRDA) Download of Trending Information to Any Hand Held Palm Pilot or Palm Cell Phone Device**
- **Automatically Uploads All Files to Computer and Converts Information to Excel Graph**
- **Documents \$ Costs for Over Lubricating Cylinders and Rod Packing**

proflo Model PF1 Divider Block Monitor & No-Flow Shutdown Protection



SA US
C 203633
CI I, Zone 2; AEx md IIC T4A
CI I, Div 2; Grps. A,B,C,D; T4A

U.S. Patents # 6,823,270 - 6,850-849 B1

Download to Palm Pilot Shows Complete History of Divider Block Operation:

- Total Oil Consumption
- Compressor Run Time Hours
- Compressor Operational Days
- Over Lubrication Costs

Reliable No Flow Shutdown Protection WITH A FULL 3 YEAR WARRANTY

- 3 year full warranty
- 3.3 volt hermetically sealed, high temperature battery... 5 year warranty and up to 10 year battery life
- AC or DC operation. Switch rated for 300 VDC & 120 VAC @ .5 amps
- Patented, sealed magnet assembly, NO lost magnets, springs or spacers.....EVER
- Heavy duty magnet housing eliminates possibility of failure caused by bending
- Proximity switch output is standard with every unit
- Hall effect activated “unlimited duty cycle”... lifetime warranty

proflo Jr.



U.S. Patent # 5,835,372



SA US
C 203633
CI I, Zone 1; AEx md IIC T4A
CI I, Div 1; Grps. A,B,C,D; T4A

Pumps and Gear Boxes

Retrofit for Graco/Trabon "MVB", Lincoln MCLP and American Bosch Gear Boxes and Pumps



CPI System on Cooper GMV10



HVLV Pump 7 & 10 MM
HVLV Gear Box with HVLV Pumps

2 Year Warranty on All Pumps



Ariel, Ajax, Gemini Pressurized Suction Pumps 1/4"-3/8"-3/16"



In Stock Replacements for All Box Suction Lubricator Pumps: Lubriquip, Lincoln, Graco/Trabon, SB, Manzel, Premier



Pressurized Suction with Sight Glass for All Rotary Vane Vapor Recovery Compressors

High volume lube pumps and gear boxes for all Clark, Cooper Bessemer, Ingersoll Rand, Ariel and Worthington slow speed and high speed engines and compressors

Replacement Lubricator Pumps for All OEM Engines and Compressors

We Stock Lubricator Boxes For All Engine and Compressor Applications



Ariel 1 Pump



Ariel 2 Pump



Gemini

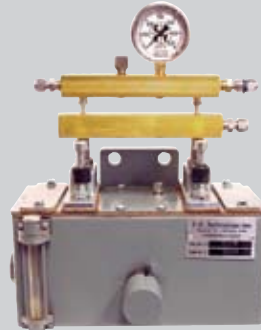

Ingersoll Rand RDS-HOS

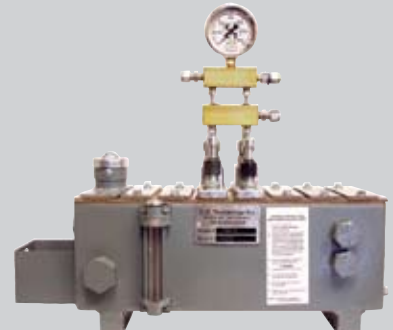

Worthington Cub & Super Cub

2 Year Warranty on All Lube Boxes



White Superior



Ingersoll Rand VIP

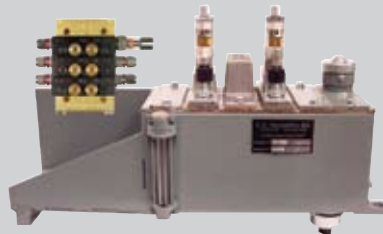

AJAX Special: 1 Pump for Engine - 1 Pump for Compressor

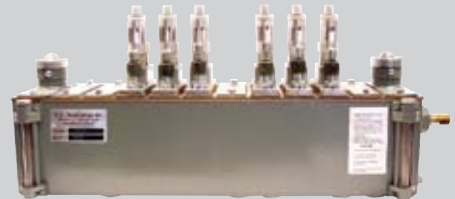

AJAX DPC60-80-105-115-140-180-260-280-300-360-600-800

OEM and Replacement Lube Boxes and Pumps to Retrofit: Ariel, Trabon, Lubriquip, Manzel, Ajax, Lincoln, Dropsa, Premier, Progressive, Chicago Pneumatic, Energy Industries, Ingersoll Rand, Cooper Axis, Dresser-Rand, Gemini, White Superior, Worthington Cub, Cooper Bessemer, Clark



CPI - CC Technology
3201 West Wall St. Midland, Texas, 79701
Office: (432) 520-6700 - Fax: (432) 520-6707
U.S. & Canada Toll Free: 1-800-664-4033
www.cct.nu



CPI - Premier & Progressive Lubrication
14028 Aston Avenue
Houston, Texas 77040, USA
Phone: (713) 462-1061 - Fax: (713) 462-4027
www.progressive-equipment.com

ELIMINATE CHECK VALVE FAILURE

5 YEAR WARRANTY FOR DIVIDER BLOCK SYSTEM CHECK VALVES

FEATURES:

- Provides oil barrier to protect the check valve sealing surfaces from hot gas and trash in the gas stream.
- Minimum fill capacity allows immediate delivery of oil to cylinders and packing.
- Pressure gauge port enables the operator to visually see when the rod packing is failing.
- Light weight and heavy duty connector eliminates failure due to vibration.
- Integral tube connector reduces leak paths.

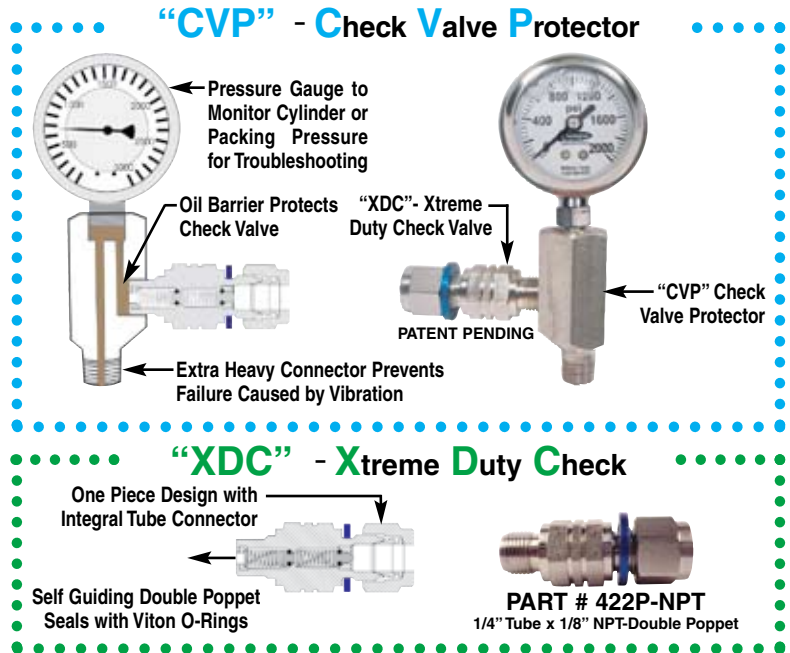

The XDC installed with the CVP will Eliminate Check Valve Failure caused by heat and gas stream contamination.

Replacement Check Valves for All OEM Compressors and Divider Block Systems



0-950014-SMA0018-1/8" - FXM
Clark, Energy Industries Cooper
Bessemer, Ingersoll Rand, Premier



950014-1/4"x1/4" - FXF
Ariel, Graco/Trabon,
Lincoln, Lubriquip, SB



0-950014-SMA0014-1/4" - FXM
Dresser-Rand – RDS-RDH-HOS-HHE,
Gemini, White Superior, Worthington Cub

“SPTD” Single Point Test Device

- The compressor industry’s ONLY device capable of testing the quantity of oil injected into a single lubrication point, with the compressor running under actual operating temperatures and pressures.
- Tests the reliability of the divider block and lube pump to determine possible cause of premature failure of cylinders, rings and rod packing.



PURGE & TEST GUN

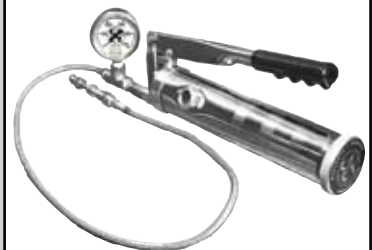

- Pre-Lube Cylinders and Packing
- Pressure Test Divider Blocks
- Purge Air from Lube System prior to Compressor Start-up

Monitor and Totalize Your Engine and Compressor Oil Consumption

Oil Make-Up Meter and Transmitter Designed for Engine and Compressor Applications



Electronic Flow Transmitter Operation

As the gears rotate, a magnet on each end of the gear activates the reed switch to send a pulse to a PLC, digital control panel or digital counter to accurately monitor oil consumption of all engines and compressors.



Electronic Flow Meter Operation

Oil consumption is displayed on the LCD in pints, quarts or liters and is totalized in gallons or liters. Designed to accurately track oil usage of all engines and compressors.

NEVER REPLACE A RUPTURE DISC AGAIN!

No More Oil Spills on the Compressor
No More Blown Rupture Discs



Replaces All Atmospheric Rupture Assemblies on Divider Block Systems

U.S. patent # D597,630S



POPTM
Patent Pending

Installed in Place of Rupture Assembly
Diverts Oil to Lube Box When System Over Pressures

No More Oil Spills on the Compressor

Remove the Old Atmospheric Rupture Assembly & Install the "POP" ... It's that Easy

"POP" POP OPEN PRESSURE RELIEF

Increase Efficiency and Reliability of All Divider Block Systems Operating at High Pressure

The divider block system operates efficiently, only when pressure differentials between injection points in the system do not exceed 1000 PSI. If the system is not balanced properly, the pressure can cause the pistons to wear prematurely and allow the oil intended for the high pressure injection point to flow around the worn piston to the point with least resistance (lower pressure). By-passing oil will cause serious damage or premature failure to the compressor cylinders, pistons, rings, rod and packing gland.

Eliminates Premature Wear of Divider Blocks and Reduces Piston By-Passing
Eliminates Blown Rupture Disc Problems - Simplifies Balancing the Divider Block System

"BVA" Balancing Valve Assembly



System Filters

509042
High Pressure In-Line Filter



Maximum Protection for System Components

1212-B118
Low Pressure Filter Adapter



Operator Can Easily See It's time to Change the Filter

809052SS
Stainless Steel Filter Element
Has 6 Times Filtering Capacity of Sintered Bronze element



S.S. Ten Micron Filter Element Is Not Affected by Any Type of Contamination



CPI - CC Technology
3201 West Wall St. Midland, Texas, 79701
Office: (432) 520-6700 - Fax: (432) 520-6707
U.S. & Canada Toll Free: 1-800-664-4033
www.cct.nu



CPI - Premier & Progressive Lubrication
14028 Aston Avenue
Houston, Texas 77040, USA
Phone: (713) 462-1061 - Fax: (713) 462-4027
www.progressive-equipment.com

“XD” Extreme Duty Divider Blocks

When You Can't Afford Compressor Downtime!

Compressor Industry's Next Generation of Superior Divider Blocks

Made in USA

US PATENT #7,096,889
Other US Patents Pending

For All Engine & Compressor Applications

“XD”™ Divider Block
Extreme Duty Divider Block

US PATENT #7,096,889

www.cci.nu

- Dual Base Plate Mounting Pattern**
Enables Use of the “XD”4 Bolt Block or 2 Bolt Graco/Trabon Style Divider Valves
- Added Mass Around Piston**
Decreases Stress Strain Expansion
- 2 Year Warranty**
- Mounting Screws Rest on Top of the Divider Block**
Eliminate Piston Bore Distortion
- Four Allen Head Bolts**
Distribute Torque Evenly Across Divider block
- Reduced Leak Paths**
Inlet and End Sections Machined as One Piece
- Inlet Check Valve**
Traps Oil in Divider Block to Prevent Reverse Flow in High Pressure Service
- 2 Inlet Points (Top & Bottom) to Hydraulic Circuit**
Allows a Pressure Gauge To Be Mounted Directly to Top or Bottom of Divider Block
- O-Ring Seal Outlets**
Requires No Thread Sealant & Accept NPT or O-Ring Sealed Outlet Check Valves
- ONE PIECE O-RING SEAL CHECK VALVES W/ INTEGRAL TUBE CONNECTION**
- SAE Threads**
Enables The Use of Industry Standard Accessories, (Cycle Indicators, Shutdown/Monitoring Devices etc.)
- Dual Purge Ports**
One On Each Side of The Base Plate Allows Efficient Purging of Air From The Divider Block Assembly

US PATENT #7,096,889
US Patents Pending

Compressors are running longer and harder in our industry & demand proper lubrication for efficient operation & longevity

“XD” Extreme Duty divider blocks are available in a wide range of piston sizes to ensure precise quantities of lubrication are injected to your rings, rods & packing

PART #	DESCRIPTION	OUTPUT In ³
XD-6T	.006 twin	.006
XD-6S	.006 single	.012
XD-9T	.009 twin	.009
XD-9S	.009 single	.018
XD-12T	.012 twin	.012
XD-12S	.012 single	.024
XD-15T	.015 twin	.015
XD-15S	.015 single	.030
XD-18T	.018 twin	.018
XD-18S	.018 single	.036
XD-21T	.021 twin	.021
XD-21S	.021 single	.042
XD-24T	.024 twin	.024
XD-24S	.024 single	.048
XD-30T	.030 twin	.030
XD-30S	.030 single	.060

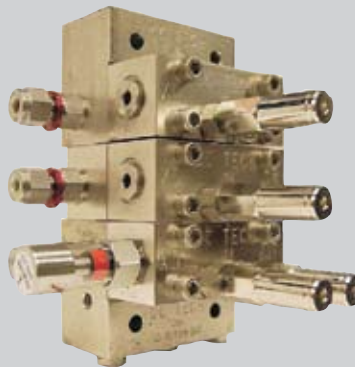

U.S. patent # 7,096,889

Base Plate Ordering Information		
Max Outlets	Divider Blocks	Part Number
6	3	XD3BP
8	4	XD4BP
10	5	XD5BP
12	6	XD6BP
14	7	XD7BP
16	8	XD8BP

**Blocks Work at
a New Level
— 8000 PSI**

“XD” divider block assemblies consist of three (3) to eight (8) working sections, one (1) inlet section with integral intermediate, one (1) intermediate section for each working block, and one (1) end section with integral intermediate. A single assembly can feed from one (1) to sixteen (16) lubrication points.

Individual blocks marked “T” for “Twin” provide separate outlets to inject oil into two (2) lubrication points. Individual blocks marked “S” for “Single” are drilled internally to combine both outlets to double the output of lubrication to a single lubrication point.

CPI Lubrication Group
PROTECTING COMPRESSORS WORLDWIDE®

ELIMINATING DIVIDER BLOCK PROBLEMS WORLDWIDE

2 TO 5 YEAR WARRANTY FOR ALL PRODUCTS

24 Hour Parts-Service and Technical Support

Visit Us on the Web: www.c-p-i.com

**System Design - Full Color CAD Documentation - Full Inventory of
Lubricator Boxes, Pumps and Accessories - 24/7 Technical Support**

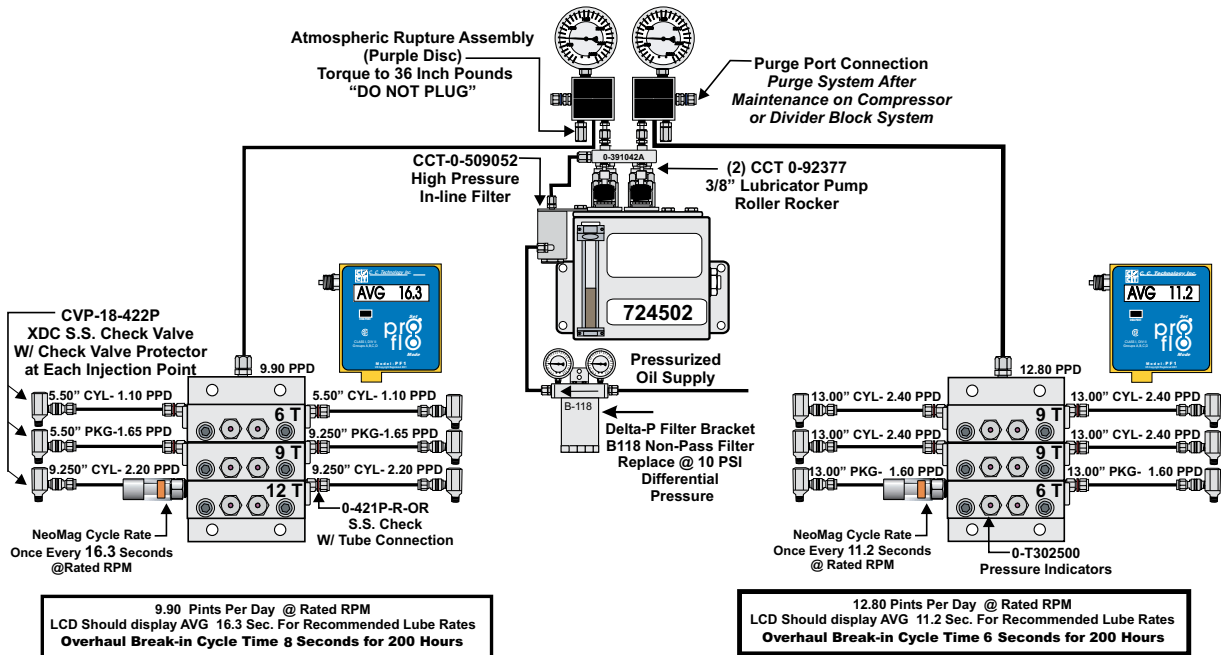

**Professional Turnkey Installation and On Site Training for
Operation and Maintenance of the Divider Block System**

*ALL TRADEMARK NAMES ARE THE PROPERTY OF THEIR RESPECTIVE COMPANIES AND NOT ASSOCIATED WITH CPI